



# NELMOR-GRANULATE

## MB HEAVY DUTY SERIES 1524-2072



### G SERIES MB HEAVY DUTY GRANULATORS

AEC's MB heavy-duty central granulators are designed for high capacity central reclamation. They can granulate a wide range of plastic scrap, from low density fiber to thick, high molecular weight purgings and can be integrated with a variety of handling equipment.

### STANDARD FEATURES

- High shear rotor
- Internal surfaces machined for ease of cleanout and material flow
- Heavy duty double roller bearings mounted outboard to avoid contamination
- Designed for high capacity central reclamation

### OPTIONS

- Water cooling
- Hardfacing
- Conveyors with amperage feedback systems
- Hog style rotor with "raised" bed knife



1100 E Woodfield Road  
Schaumburg, IL 60173 USA  
Tel. 847-273-7700 Fax 847-273-7804

www..com



**WHITLOCK/  
MATERIAL  
HANDLING**



**HEAT & COOL**



**BLEND &  
RECLAIM**



**NELMOR/  
GRANULATE**



**DOWNSTREAM  
EXTRUSION**



**AUTOMATE**



**SYSTEMS  
CONTRACTING**



**SERVICE**



# NELMOR-GRANULATE

## MB HEAVY DUTY SERIES 1524-2072

Specifications	G1524MB	G1828MB	G1837MB	G2050MB	G2062MB	G2072MB
Throat Size	15"x24"	18"x28"	18"x37"	20"x50"	20"x62"	20"x72"
Cutting Circle	14"	16"	16"	18"	18"	20"
Throughput (3/8" screen)	1000	1800	2500	3500	4500	5000
Infeed	Conveyor					
Cutting Chamber	(2) Bed					
Rotor	Open 3 Blade					
Rotor Knives	(3) HCHC					
Bed Knives	(2) HCHC					
Screen Diameter	3/8"					
Base	Step Type					
Discharge	Airveyor					
Motor (tefc)	75 hp	100 hp	100 hp	150 hp	200 hp	200 hp
Drive	V-belt					
Electrical Components	Safety switches wired to common junction box					
Controls	To suit voltage, 100V at operator station					
Labels	Safety labels are provided for proper operation and maintenance					
Accessories	Available upon request					
Feed Height	90"	104"	104"	112"	112"	112"
Length	53"	46"	46"	46"	46"	46"
Width	73"	117"	135"	140"	145"	171"
Height	107"	135"	127"	164"	164"	164"
LxWxH (mm)	1346x1854x2718	1168x2972x3429	1168x3429x3226	1168x3556x4166	1168x3683x4166	1168x4343x4166
Weight (lbs.)	6000	7000	11,000	15,000	22,000	26,000

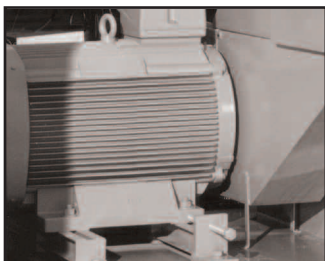
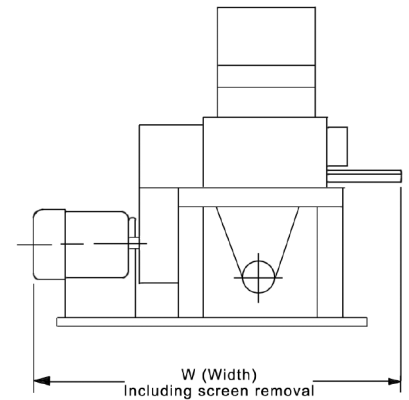
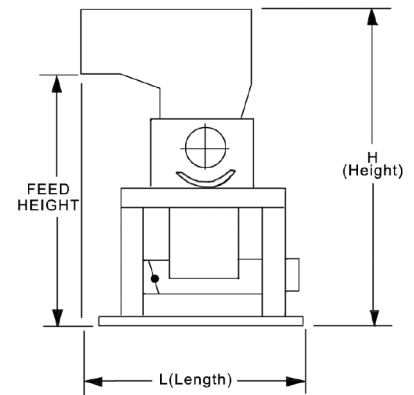

Outboard mounted motor with "heavy duty" flywheel

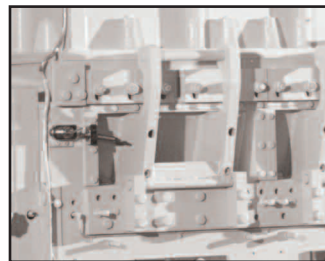

Drop down screen cradle for access during knife change and cleanout



1100 E Woodfield Road  
Schaumburg, IL 60173 USA  
Tel. 847-273-7700 Fax 847-273-7804

www.  .com



**WHITLOCK/  
MATERIAL  
HANDLING**



**HEAT & COOL**



**BLEND &  
RECLAIM**



**NELMOR/  
GRANULATE**



**DOWNSTREAM  
EXTRUSION**



**AUTOMATE**



**SYSTEMS  
CONTRACTING**



**SERVICE**